

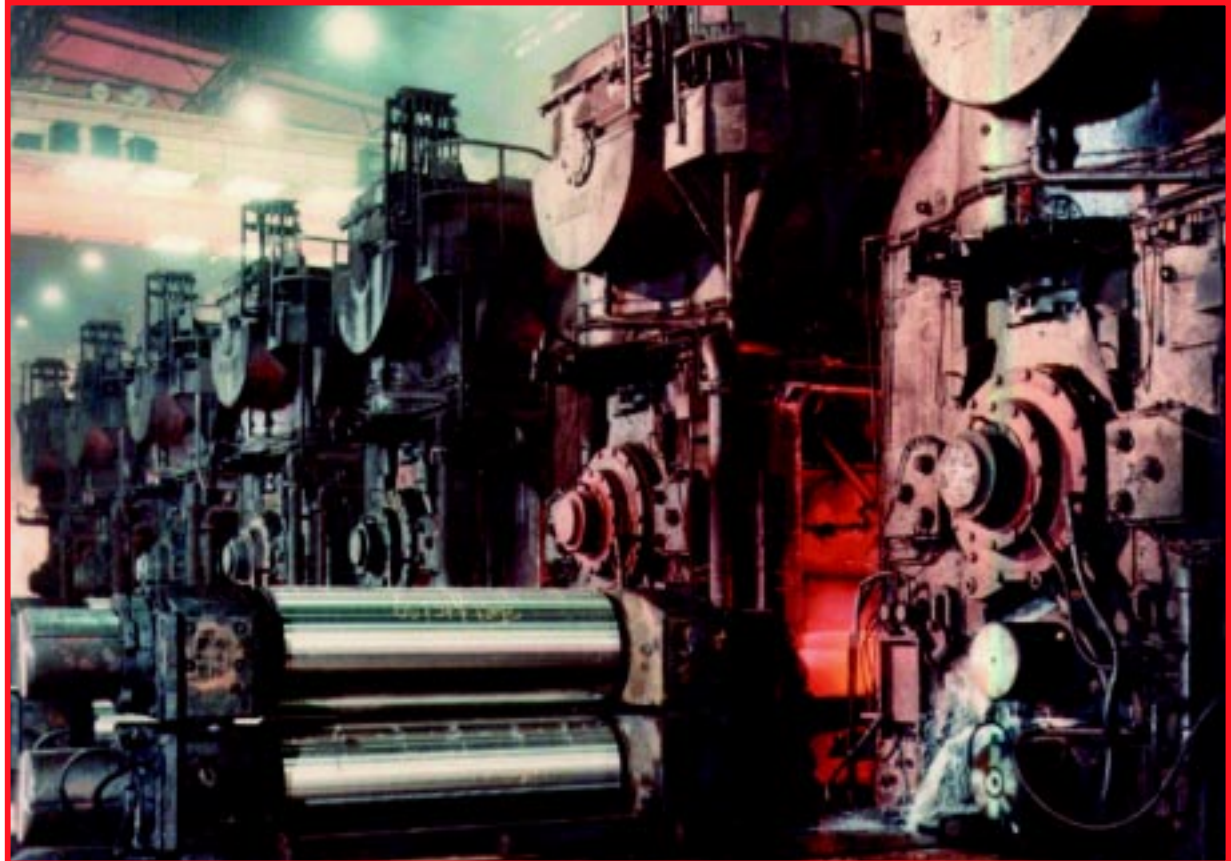

**JARRET SPRINGS
FOR AUTOMATIC WORK ROLL CHOCK SEPARATION**





INTRODUCTION

JARRET devices are designed and built on the principle of the compression, and the shear characteristics, of specially formulated proprietary silicone compounds.

These characteristics enable the JARRET device to be designed as an energy storing device (a spring)

or an energy dissipating device (a shock absorber) or a combination of both.

By modifying the geometry of the unit and selecting an appropriate silicone compound, emphasis can be placed either on the energy storing function or on the energy dissipating function.

OPERATING CONDITIONS OF THE JARRET SPRING

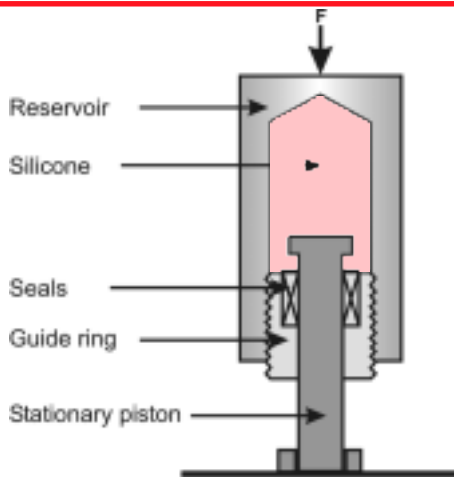

The load "F" forces the reservoir over the stationary piston. The silicone is compressed by the volume displacement of the stationary piston.

Advantages:

- 1 - Extremely compact.
- 2 - Dependable retention of initial characteristics, even after years of non-use.
- 3 - Easy installation.
- 4 - No maintenance.
- 5 - No adjustment necessary in service.
- 6 - Elimination of any additional devices for pre-loading because the silicone has been pre-stressed during initial charging.
- 7 - Appreciable service life: in normal operating conditions it may reach 5 to 10 years.

JARRET SPRINGS FOR AUTOMATIC WORK ROLL CHOCK SEPARATION

The weight of the top work roll and chock assembly is supported on two or four JARRET springs. The units are pre-stressed to a load approximately 10% higher than the weight of the top roll assembly. Consequently, when the top roll assembly is resting on the springs, there is no movement or compression.

When the top back-up roll is forced down on the top work roll to the desired roll gap, the JARRET units are compressed and remain in the compressed position during the rolling operation.

When the top back-up roll is removed, the JARRET units force the top work roll and chock assembly upwards to their fully extended position, maintaining the two work rolls at a constant center-to-center distance.

The JARRET spring is located in a vertical cavity in the bottom work roll chock, with the piston facing down, resting on the bottom of the cavity or on a replaceable thrust plate..

The JARRET device acts as a compact, high-quality dependable spring:

- a) It maintains the top work roll assembly in an elevated position when the mill is not running, yet does not interfere with the rolling operation.
- b) The work rolls are maintained separated at a constant

center-to-center distance during installation, removal and transfer of rolls.

- c) The rolls are prevented from coming into contact with one another, thereby avoiding damage to the roll surfaces.
- d) The use of JARRET springs eliminates the need to jack up the top work roll and then block or latch for correct roll separation on fixed centers. In doing so it eliminates the need for additional shimming required for the safe and stable transportation of roll assemblies and obviates the need for troublesome latching mechanisms.
- e) The use of JARRET springs "*reduces time required for roll changing*" to one-fourth of the time taken by conventional methods.
- f) In some applications JARRET springs can be used for back-up roll counter balance.

By the use of hydraulic pressure under the JARRET springs, the top work roll assembly may be raised higher than the normal extended position the spring allows. This is achieved by the hydraulic pressure raising the complete spring off its seat in the base of the cavity. During rolling, this hydraulic pressure may be used to create upward forces to correct roll bending, reduce work roll skidding or counterbalance the top back-up roll.

DATA REQUIRED TO SELECT A JARRET SPRING

D.C.1 Common reservoir end designs

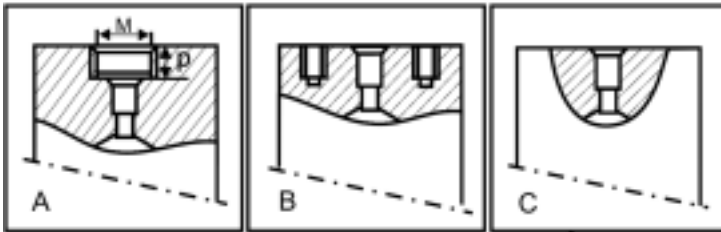

D.C.2 Common reservoir configurations

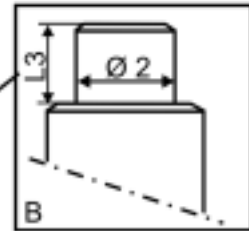
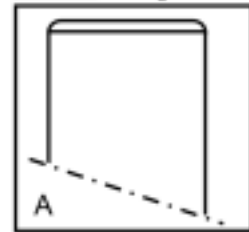

D.C.3

Cadmium plated	Hard chromed	No Protection
A	B	C

CM

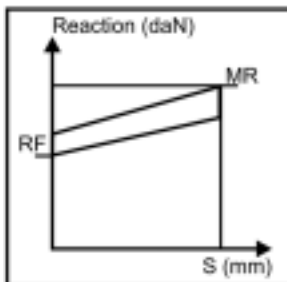

RF : Recalling Force = (weight x 1.1)
MR : Maximum reaction
S : Stroke

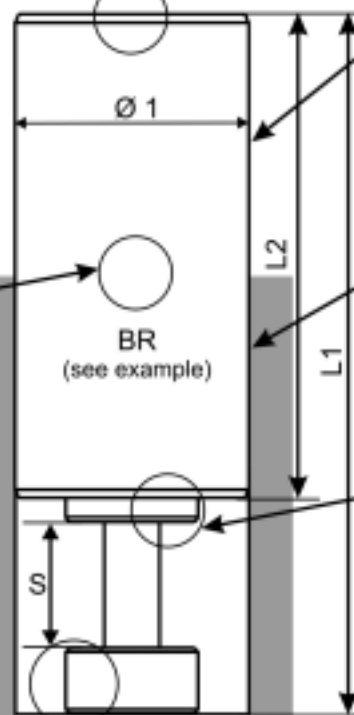

D.C.4 Piston rod collets with and without provision for hydraulic seals

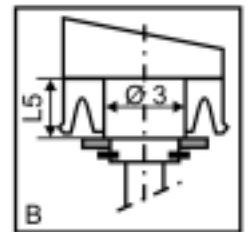
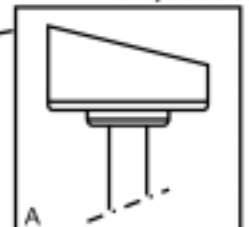

D.C.5 End of piston with or without provision for hydraulic fluid entry

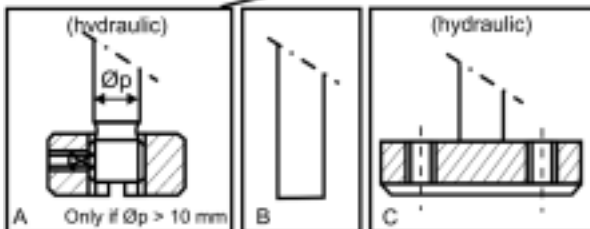

NOMENCLATURE

- CM** = Mechanical characteristics
RF ; MR ; S
- CG** = Geometrical characteristics
L1 ; L2 ; L3 ; L4 ; L5 ; Ø1 ; Ø2 ; Ø3 ; M ; P
- DC** = Details of design
1 (A, B, C) ; 2 (A, B) ; 3 (A, B, C) ; 4 (A, B) ; 5 (A, B, C)

NOTE

Example of nomenclature of the JARRET Spring shown above
CM : RF 11000 ; MR 33000 ; S 45
CG : L1 220 ; L2 152 ; Ø1 80
DC : 1C ; 2A ; 3A ; 4A ; 5B



SPRINGS FOR AUTOMATIC WORK ROLL CHOCK SEPARATION

Stroke calculation:

S = maximum diameter - minimum diameter + d + extra

S = center to center distance - minimum diameter + extra

Load per JARRET spring

Calculation:

Top work roll chock assembly weight divided by total number of JARRET springs used (generally two per chock).

Note:

JARRET springs may also be used as plungers in combination with hydraulic pressure (as for roll bending, etc ...)

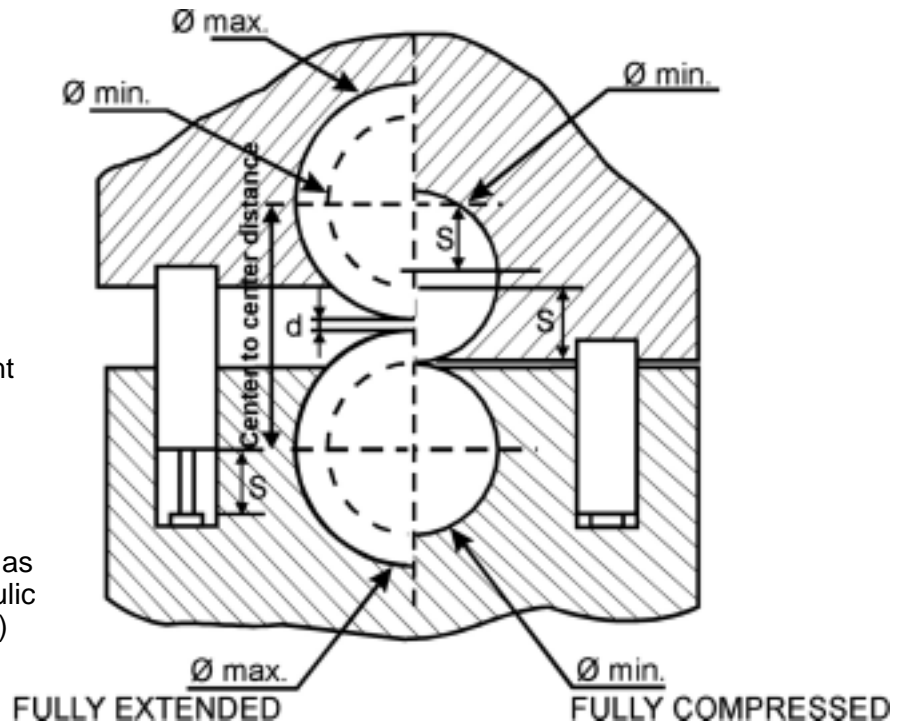

Hysteresis

The actual hysteresis is between 5 and 10 percent and does not in practice negatively affect strip shape control or AGC.

Temperature

JARRET Springs use silicone compounds that retain their properties over a wide temperature range. However, since their coefficient of expansion is greater than that of steel, a variation in temperature causes a change in force level. All force values listed for any spring are rated at a temperature of +20° C.

- Allowable extremes: - 40° C to + 70° C
- Recommended limits: - 20° C to + 50° C

Applications

Hot strip mills, Cold strip mills, Skin pass mills, Tin mills, Temper mills, Plate mills, Slab/Bloom mills, Bar mills, Rod mills.

References (Mill manufacturers)

U.S.A.

SMS-DEMAG
DMS - BLISS
FATA-HUNTER
MORGAN CONSTRUCTION
DANIELI UNITED ENGINEERING
TIPPINS, INC.

GERMANY

SKET
KOCH
SUNDWIG
SMS DEMAG

CANADA

DOMINION ENGINEERING WORKS

AUSTRIA

VOEST ALPINE

JAPAN

I.H.I.
HITACHI

FRANCE

VAI CLECIM

Jarret, Inc.

4 Four Coins Drive
Canonsburg, PA 15317

Tel: 724/746-1600

Fax: 724/746-0660

Email: contact@jarret.com